

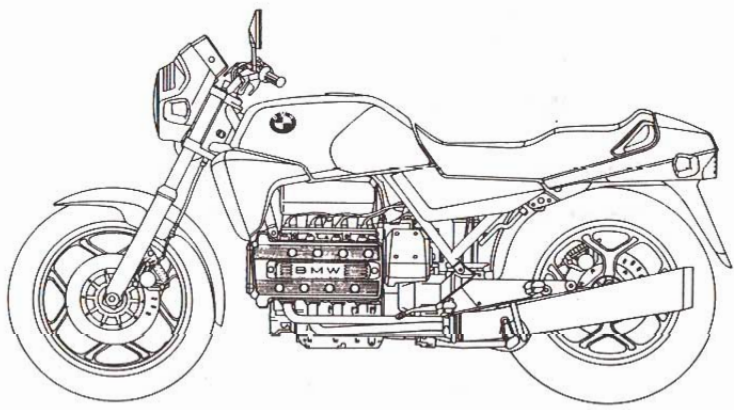

HANDBOOK

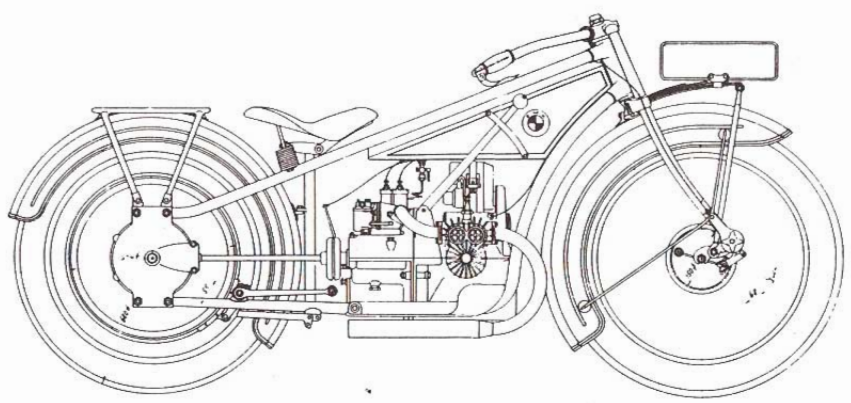

1988 - 89

THE BMW CLUB HANDBOOK
1988 - 1989

CONTENTS

TOOL HIRE SCHEME

Introduction	Page 3
Arrangements for Hire	Pages 4 - 5
Tools - Pre 1969 models	Pages 6 - 7

CLUB JOURNAL INDEX
1976 - 1987

Contents	Page 21
Categories	Pages 22 - 38

NONE-CURRENT PARTS & SPARES

Addresses	Pages 39 - 41
Recent News	Page 44

BMW CLUB TECHNICAL LIBRARY

Pages 42 - 44

BMW CLUB
TOOL HIRE SCHEME

The BMW Club owns a very large number of special tools which assist in service, maintenance, and repair of BMW motorcycles. The following pages list in detail most of the special tools produced, not all of which the Club possesses. The figure appearing in Column 1 (availability) indicates how many of each tool the Club owns. No reference in column 1 means that the tool is not available through the Club's hire scheme.

The BMW Club tool hire scheme is available only to paid up Club members, and the Club's tool hire secretaries have the authority to request evidence of current membership if they feel it is appropriate in any instance.

The tools are held in two batches. Those applicable to pre series 5 (pre 1969) machines and those applicable to series 5 and later. The address of the members acting as tool hire secretaries for each batch of tools is published on page 2 of each Club magazine.

(The work of Don Butterworth and Gerry Douglas-Sherwood in compiling this listing is gratefully acknowledged)

ARRANGEMENTS FOR TOOL HIRE

1. Prepare yourself and your motorcycle for the task you are to perform. Ensure that you have to hand all necessary tools which you do not plan to hire from the Club scheme. Try to keep to a minimum the time you will have the tools on hire. It will be less expensive for you; and may save another member having to wait for you to return a tool which he or she wishes to hire.

2. Confirm from the listing that the special tools required are available through the tool hire scheme. Note the tool part number.

THE BMW CLUB IS NOT RESPONSIBLE FOR ANY ACTION OR INJURY INCURRED THROUGH USE OF THE CLUB'S TOOLS. IT IS THE SOLE RESPONSIBILITY OF MEMBERS HIRING TOOLS FROM THE BMW CLUB TO CHECK THE SUITABILITY OF THE TOOL FOR THE TASK THEY ARE TO PERFORM WITH IT.

3. Telephone the appropriate tool hire secretary (see page 2 of a Club magazine) to confirm tool availability, and obtain deposit fee (usually between £10.00 & £50.00) and weekly hire rate (usually between £3.00 & £8.00 per week or part-week). Occasionally an additional deposit fee will be requested if special returnable package is necessary.

4. Send deposit fee to tool hire secretary.

All cheques to be made payable to "BMW CLUB TOOL HIRE".

Include a clear statement of your name, address, phone number, tool part number, and motorcycle model and year. In certain circumstances it may be advantageous to state the engine number. Briefly state job you are undertaking.

Forward cheque and details URGENTLY after speaking to the tool hire secretary. The tool/s will only be held for a few days, after which they may be dispatched to another member.

5. On receipt of your order the cheque will be paid into the Club's tool hire bank account, and the items dispatched by GPO PARCEL POST as quickly as possible with a dated delivery note stating agreed deposit and hire charges. A green GPO form will also be included for return PARCEL POST.

6. The green form is for insuring the parcel during its return journey and is applicable only to PARCEL POST (not letter post). Use of this form is obligatory. If letter post is used for very light tools it is necessary to register the small parcel.

In the parcel please include a note of your name and address and posting date. This may be helpful in the event of delay or loss.

In the event of any postal loss of tools which are not returned by insured parcel post or registered letter post the BMW Club will claim the full replacement value of the tool/s from the member. In most instances deposit charges, though reflecting the value of a tool, are only a percentage of the tool replacement costs.

It is also useful to know if members experience any special problems in using the tools hired, or if you have any advice which may be useful to pass on to future users of the tool.

7. On return of the tools the tool hire secretary checks them and confirms that they are in the same condition as when hired out.

The number of days from posting outward to being received back is divided by seven to arrive at the number of weeks hire applicable. The hire charge and mail costs, plus any telephone charges applicable, are deducted from the deposit fee. The balance is returned to the member in the form of a club cheque with a receipted invoice/statement.

+++++

NOTE: Financial security is maintained through use of a triplicate invoice system which ensures that hirer, tool hire secretary and Club treasurer are fully informed of all payments and receipts.

+++++

ANY TECHNICAL ADVICE OF ANY SORT WHICH IS GIVEN THROUGH THE PAGES OF THE MAGAZINE OF THE BMW CLUB IS SOLELY ON THE BASIS OF 'ENTHUSIAST TO ENTHUSIAST'. ENTHUSIASTS ARE NOT NECESSARILY EXPERTS IN ANY WAY. ANY MEMBER CHOOSING TO ACT ACCORDING TO ANY ADVICE GIVEN THROUGH THE PAGES OF THE MAGAZINE OF THE BMW CLUB DOES SO AT HIS OR HER OWN RISK.

+++++

1	2	3	4	5	6	7	8	9	10	11	12	13	14	15	16	17	18	19	20	21	22	23	24	25	26	27
2	1112DB350	Allen socket - 1/2" drive, to tighten cyl. head bolts																								
1	11-1-720	Tappet depressing tool - use when replacing valve shims																								
1	11-1-730	Tongs - for removing valve adjustment shims																								
1	11-1-740	Valve spring clamping jig - for removal/fitting valves (3 pieces)																								
1	11-1-747	Use with 11-1-740																								
	11-1-750	Valve spring clamp																								
1	11-1-760	Drift punch - removal valve guides from cylinder head																								
1	11-1-770	Drift punch - insert valve guides into cylinder head																								
1	11-1-780	Drift punch - 8mm valve guide removal																								
1	11-1-790	Drift punch - 8mm valve guide inserting																								
2	11-1-800	Extractor - Timing chain cover																								
1	11-1-820	Centering bush & sleeve - timing chain cover & seal insert																								
1	11-1-830	Centering bush & sleeve - " " " " "																								
3	11-1-850	Seal drift - 'O'ring seal into alternator bearing cover (use with 00-5-500)																								
	11-1-870	Extractor tool - Crankshaft bearing (use with 00-8-560)																								
1	11-1-880	Seal drift - rear crankshaft oil seal																								
	11-1-881	Spacing sleeve - use with 00-1-880 for twins from April '82																								
3	11-1-890	Rear crankshaft seal Extractor/fitting tool (with 11-1-880)																								
	11-1-900	Drift - valve guide into cyl. head																								
1	11-1-940	Drift - valve stem seal onto valve guide																								
	11-2-300	'C' spanner - gear box oil dipstick																								
1	11-2-500	Torque gauge indicator - degree settings																								
2	11-2-600	Extractor - remove duplex chain sprocket from crankshaft (5 pieces)																								
1	11-2-606	Sleeve head- use with 11-2-600 for simplex chains (from Nov. '78)																								
2	11-2-620	Drift - press chain sprocket onto cr/shaft (with 11-2-630)																								
2	11-2-630	Press-on tool (use with 11-2-620)																								
3	11-2-700	Pressing tool - remove main bearing (Order with 11-2-710)																								
3	11-2-710	Assembly tool - Remove/insert main bearing (Order with 11-2-700)																								
3	11-2-720	Pressing tool - (use with 11-2-710)																								
2	11-2-800	Clutch/flywheel Retaining rod - to prevent rotation																								
1	11-2-810	Extractor - flywheel from crankshaft (3 pieces)																								
1	11-2-860	Universal spanner - to loosen/tighten big end bolts																								

1	2	3	4	5	6	7	8	9	10	11	12	13	14	15	16	17	18	19	20	21	22	23	24	25	26	27
1	11-2-905	Piston ring clamp - R75, R80																								
1	11-2-910	Piston ring clamp - R50, R45, R65, K series																								
1	11-2-915	Piston ring clamp - R90, R100																								
1	11-2-920	Gudgeon pin drift																								
1	11-2-925	Piston ring clamp - K75, K100																								
1	11-2-930	Gudgeon pin drift																								
1	11-3-600	Sleeve - to lever camshaft off chain sprocket (pre '81)																								
1	1112DB400 -410	Torx key - M drive torx sockets size T27 & T30 for removal & fitting cam chain tensioner blade & top guide rail. Also for bellhousing/crankcase retaining screw torque setting.																								
1	11-4-600	Oil pressure gauge - standstill or travelling																								
1	11-4-650	Oil filter key - loosen/tighten oil filter																								
	HWBER81	Adaptor cable - for function check of injector valves																								
1	11-5-500	Clamping device - removal/installation of chain tensioner																								
	12-3-500	Plug spanner																								
2	12-3-600	Alternator armature removal bolt																								
1	12-3-650	Ignition timer - static timing on electronic ig. models																								
	12-3-651	Ignition timer adaptor - use with above for K100																								
	12-4-600	Counter holder - loosen nut on alt. shaft when removing driving cup																								
1	130DB103	Vacuum Carb. Synch. gauges for all twins																								
	13-0-500	Unitest synchroniser - carb. balance without vac. connectors																								
	13-0-600	Topping caps R50/5 - R60/7 To synch. carbs without																								
	13-0-610	Topping caps R75/5 vacuum connectors																								
	13-0-620	Topping caps R90S (use with 13-0-500)																								
	13-0-700	Carb. synchroniser - LE Jetronic (with 702 & 703)																								
1	13-1-500	Assembly pliers - hose clips to throttle butterfly assembly																								
1	16-1-500	Test pressure gauge - fuel pump pressure																								
1	16-1-650	Fuel starter set - to start engine with fuel tank removed																								
1	17-0-003	Adaptor for 17-0-500																								
1	17-0-004	Adaptor for 17-0-500																								
1	17-0-500	Cooling system leak test set																								
1	18-0-600	Exhaust pipe/port nut wrench																								
	1821DB450	Exhaust nut tap & die - for IMPROVING slightly damaged threads																								
2	21-2-600	Clutch clamp bolts x 3 - removal/fit clutch																								

U-1-650
DRIFT

1	2	3	4	5	6	7	8	9	10	11	12	13	14	15	16	17	18	19	20	21	22	23	24	25	26	27	
1	33-1-860	Drift - to drive 'O ring seal into housing cover																									
2	33-1-880	Drift - to drive in crown wheel sealing ring at wheel drive housing																									
1	33-2-600	Gauge - to check tooth edge play (with 33-2-620) (6 pieces)																									
	33-2-604	Gauge arm - stop for dial gauge when measuring backlash																									
	33-2-610	Gauge - to check tooth edge play (with 33-2-620)																									
	33-2-620	Locking device - to hold drive pinnion when measuring tooth edge play																									
	33-2-630	Locking device - as above (use with 33-2-600)																									
1	33-2-640	Drift - to drive brake drum sleeve out of rear axle housing cover																									
1	33-5-600	Clamp - to remove & fit telescopic legs																									
1	33-5-605	Clamp block - (use with 33-5-610)																									
	33-5-610	Thrust block - (use with 33-5-600 & 33-5-605) for removing/attaching spring struts																									
	33-5-620	Tongues - to remove/fit circlip on telescopic leg																									
1	34-0-600	Adjuster gauge - to adjust front brake master cyl. clearance																									
	34-1-500	Piston resetting device - to force back piston into brake caliper before renewing brake fluid																									
	34-1-510	Spacer - to hold back caliper piston whilst renewing fluid																									
1	36-3-613	Balancing flange for K rear wheel (use with balancing jig)																									
1	36-3-614	Balancing axle for K front wheel (use with balancing jig)																									
2	36-3-650	Peg spanner - front wheel hub cover (not cast wheels)																									
1	36-3-651	Slip on bush for 17mm axle shaft (use with 36-3-650)																									
2	36-3-700	Drift - to remove wheel bearing (not cast wheels)																									
1	3631DB310	Extractor - to remove wheel bearing outer ring																									
2	36-3-800	Spoke nipple wrench																									
1	36-3-820	Spoke gauge - to spoke 18" or 19" wheels with drum brakes																									
1	36-3-850	Spoke gauge - to spoke wheels with eccentric spokes and/or disc brakes																									
1	36-3-880	Assembly tongue - to fit balancing weights on cast wheels																									
	46-5-604	Steering head drift - (use with 31-4-820)																									
	46-5-605	Locking lever - (use with 31-4-820)																									
1	46-5-606	Gauge bolts for use with frame jig (2 pieces)																									
1	46-5-700	Lever - to lever mirror out of rear view mirror plate																									
1		Rocker assembly jig (5)																									
1	02568/1	Fork top cap pin wrench (5 & 76)																									
1		10mm Allen key welded to 1/2" drive																									

THE BMW CLUB JOURNAL

INDEX

1976 - 1987

SUBJECT ITEM	PAGE
Engine & Lubricants	22
Fuel Supply & Mixture Control	23
Fuel Tank & Lines	23
Exhaust System	23
Clutch	24
Gearbox	24
Front Forks	24
Steering	24
Rear Wheel Drive & Suspension	25
Brakes & Pedals	25
Wheels & Tyres	26
Frame	27
Instruments	27
Engine Electrical System	28
General Electrical System	29
Servicing, Tools & Parts	30
General Articles	31
Road Test, Riding Experiences & New Models	32
Clothing, Protective Gear, Luggage & Accessories	34
Insurance	35
Racing	35
Touring	36
Vintage & Veteran	37
Rallies	38
Trials	38
Sidecars	38

(Grateful acknowledgements to BMW Club member Stephan
Bentall for compiling this index)

ENGINE & LUBRICANTS

PAGE	MONTH	YEAR	TYPE	
<u>Lubricants & Oil Consumption</u>				
9	8	87	R	VALVOLINE & FILTRATE OILS
9	8	86	R	LONG LIFE OIL
11	3	86	R	WYNN'S ADDITIVE
8	2	86	K	MOBIL RALLY 15W50
9	2	86	R	HIGH OIL CONSUMPTION
8	1	82	R	HIGH OIL CONSUMPTION
11	1	82	R	SHELL ROTELLA OIL
10	10	81	R	OIL VISCOSITY R60/2 1964
14	6	81	R	LUBRICANTS & SPECIFICATIONS
18	4	80	R	ENGINE LUBRICATION, CRITICAL VIEW
20	6	78	R	9EL RAY 10W40
9	3	76	R	CRITICAL OIL LEVEL, R 90S & OTHERS
<u>Timing Chains</u>				
8	1	87	R	RENEWAL - RICCORS
8	6	84	R	RENEWAL
10	5	84	R	RENEWAL
17	4	80	R	LOOSE TENSIONER
12	1	79	R	STRIP DOWN, /5 /6 /7 MODELS
13	4	76	R	RATTLE /5 /6 MODELS
<u>Oil Filters</u>				
8	7	86	K	OIL FILTER WRENCH, SUPPLIER
8	4	86	K	OIL CHANGE PROBLEMS
9	4	86	K	RELEASE OF CARTRIDGE
8	2	86	K	REPLACEMENT, POST FIRST SERVICE
11	2	85	K	TOOL ALTERNATIVE
12	9	83	R	COLLAPSE
16	7	83	R	CORRECT ASSEMBLY
19	6	82	R	EMGO PATTERN COLLAPSE
16	12	81	R	CHANGE DIFFICULTIES
12	9	81	R	PURDLATOR COLLAPSE
11	9	80	R	DONIT PATTERN COLLAPSE
29	9	80	R	DONIT PATTERN, REMOVAL BY BMW
14	7	80	R	DONIT & PURDLATOR COLLAPSE
10	6	80	R	PURDLATOR COLLAPSE
<u>Crankshaft Rear Oil Seal</u>				
17	12	83	R	REPLACEMENT
17	11	83	R	REPLACEMENT
18	10	82	R	ALTERNATIVE SUPPLY
16	6	82	R	FAILURES ON RICCORS '81
17	12	81	R	IMPROVED PATTERN
12	9	81	R	FAILURE
19	8	80	R	REPLACEMENT PROCEDURE
14	10	77	R	/6 SERIES, DATSUN ALTERNATIVE
<u>Lappet Clearances</u>				
12	10	87	K	VALVE SHIM CLEARANCES
8	9	87	K	VALVE SHIM CLEARANCES
22	8	87	K	VALVE SHIM CLEARANCES
11	2	82	R	ADJUSTMENT
15	12	81	R	ADJUSTMENT

PAGE	MONTH	YEAR	TYPE	
<u>Exhaust Flange Threads</u>				
19	9	87	R	EXPERT REPAIR
9	8	87	R	WRONG USE OF GASKET CEMENT
8	1	87	R	EXPERT REPAIR
12	11	78	R	STRIPPED
<u>Valves & Guides</u>				
8	4	87	R	OIL SEALS
7	1	86	R	OIL SEALS, FITTING ON R90S
7	10	85	R	DROPPED VALVE, R80/7
8	8	85	R	DROPPED VALVE
12	7	81	R	DROPPED VALVE, R100/7
11	10	79	R	SPRING FRACTURE, R45
13	3	77	R	GUIDE MATERIAL, CHOICE
7	10	76	R	GUIDE DAMAGE, R75/5
<u>Unclassified</u>				
14	12	87	K	COOLANT LEAK CURE
14	12	87	K	WATER PUMP REPAIR
16	4	87	R	UPGRADE R80 to R100
8	1	87	R	ROCKER BEARINGS, BROKEN CAGES
7	12	86	R	ROCKER SHAFT ENDFLOAT, UPDATING
7	10	86	R	OIL PAN MOD. /5 REPLACED BY /6
12	9	86	R	OIL PICK-UP LOOSE IN SUMP
11	8	86	K	THIRD OUTPUT SHAFT FAILURE
12	8	86	R	OIL PICK-UP LEVEL CORRECTION
7	7	86	R	CON ROD FAILURE, R65
7	7	86	R	ROCKER ARM SHAFT, END FLOAT
10	7	86	R	PISTON TOLERANCING
14	5	86	R	OIL PICK-UP PAN, FATIGUE FAILURE
21	5	86	R	ENGINE REBUILD, R50
11	4	86	K	OIL LEAKS, PUMP & CAM CHAIN COVER
12	7	85	R	NEPOLITE APEX PISTONS
11	5	85	R	ENGINE VIBRATION, R65
9	3	85	R	ENGINE VIBRATION, R65
15	12	84	K	OIL LEAKS
14	11	84	R	CONVERSION, R45 to R60
16	11	84	R	OIL LEAK, ALTERNATOR COVER
21	10	84	R	ROCKER ARM END FLOAT, ADJUSTMENT
13	12	83	R	ROCKER ARM NEEDLE ROLLERS MIGRATING
15	12	83	R	SUMP BOLTS, OVERTIGHTENING
17	12	83	R	CRANKCASE PRESSURE RELEASE VALVE MODS.
15	11	83	R	PRESSURE RELIEF VALVE, FILTER COLLAPSE
14	10	83	R	CRANKCASE PRESSURE RELIEF VALVE
17	8	83	R	ROCKER ARM END FLOAT - CLAMPING
15	7	83	R	CONVERSION R45 TO R65, DETAILS
14	5	83	R	CONVERSION R45 TO R65, FEASIBILITY
11	1	82	R	ENGINE REBUILD, R100S '80
15	12	81	R	OIL TEMPERATURE, SHORT JOURNEYS
15	10	81	R	FUEL CONSUMPTION, R100S '80
12	9	81	R	ROUGHNESS/VIBRATION, REBUILD R100S
14	3	81	R	EXCESSIVE VIBRATION, R65
8	1	81	R	PUSHROD SEALS, SILICONE JELLY FIX
22	11	80	R	OIL COOLER, FITTING ROUTINE, R90S
13	9	80	R	OIL COOLER, BLEEDING
15	9	80	R	TIMING & DETUNING OF ENGINES, REVIEW

PAGE	MONTH	YEAR	TYPE	
10	6	80	R	OIL PICK-UP PAN LOOSE, RESULTS
8	1	80	R	ROCKER NEEDLE ROLLER BEARINGS ASSEMBLY
15	4	79	R	/5 TO /6 ROCKER UPDATE
15	4	79	R	BUDGEON PIN RETAINING CLIP, '79 UPDATE
12	11	78	R	LOWER COMPRESSION RATIO, R60/7
22	6	78	R	ROCKER ARM CONVERSION KIT, /5
5	9	77	R	PINKING, R60/6 (HIGH COMPRESSION)
5	7	77	R	R75/6 - R60 MODIFICATIONS
12	6	77	R	R27 PROBLEMS
14	1	77	R	CRANKSHAFT TOLERANCES, R75/5
6	12	76	R	BEARING SPECS - REPLACEMENT
9	3	76	R	OIL LEAKS, /5 & /6
4	1	76	R	OIL LEAKS, COMMENTS

FUEL SUPPLY & MIXTURE CONTROL

PAGE	MONTH	YEAR	TYPE	
<u>Fuel Filter</u>				
12	8	87	K	SPLITTING
11	5	87	K	SPLITTING
10	8	86	K	SPLITTING
15	5	86	K	SPLITTING
11	10	85	K	SPLITTING
<u>Unspecified</u>				
25	1	88	K	NONE RETURN VALVE, REPLACED
25	1	88	K	THROTTLE FAULT
8	10	87	K	INJECTOR COVER FOULING FUEL PIPE
14	10	87	K	FUEL LEAK, CAUSING FIRE
8	5	87	K	FUEL SURGING (low fuel pressure)
8	7	86	K	COMPUTOR BOX REPLACEMENT
8	7	86	K	FUEL PUMP REPLACEMENT
11	4	86	K	FUEL RETURN VALVE RATTLE
11	10	85	K	FLOODING IN COLD WEATHER
11	10	87	R	MIXTURE STRENGTH ADJUSTMENT
21	8	87	R	BALANCING TWINS
9	4	87	R	FUEL FILLER CAP VENT BLOCKAGE
18	3	87	R	CARB. DIAPHRAGM REPLACEMENT
19	3	87	R	CHOKE BUTTERFLY SPINDLE SEIZURE
13	8	85	R	FLAT SPOT CURE, R65LS '82
7	2	86	R	DELL-DRTO CARBS, R90S
7	2	86	R	DIAPHRAGM COVER LOOSE, R80 '85
12	12	85	R	MISFIRING, WATER IN FLOAT CHAMBE
7	11	85	R	THROTTLE CABLE WEAR
22	6	85	R	INLET MANIFOLD MOD, R100 '81
11	5	85	R	CHOKE RETURN SPRING FATIGUE
8	2	85	R	FUEL CONSUMPTION, R80S
18	4	83	R	FUEL CONSUMPTION, R80/7
12	10	87	R	THROTTLE FRICTION SCREW ADJUSTMENT
26	9	87	R	CARB. MAINTENANCE & ADJUSTMENT
20	8	87	R	CARB. MAINTENANCE & ADJUSTMENT
13	11	80	R	CHOKE CABLE FOULING FUEL TAP, /5
18	10	80	R	FUEL CONSUMPTION, ASSORTED COMMENTS
16	12	79	R	CV CARB. DESCRIPTION
12	6	77	R	CARB. PROBLEMS, R27

FUEL TANK AND LINES

PAGE	MONTH	YEAR	TYPE	
25	1	88	K	FUEL TANK REPLACED
14	1	87	R	8 GALLON STEEL FUEL TANK
11	8	86	R	FILLER CAP FAILURE
9	2	85	R	FUEL TANK CONDENSATION, WATER INGRESS
32	2	86	K	FUEL FILLER CAP, MODIFIED
10	6	85	K	HOT TANK PROBLEMS
12	12	85	R	WATER IN FUEL TANK
15	11	84	R	FILLER CAP REMOVAL, EMERGENCY
15	9	84	R	FILLER CAP REMOVAL, EMERGENCY

EXHAUST SYSTEM

PAGE	MONTH	YEAR	TYPE	
<u>Steel Steel Silencers</u>				
9	10	87	K	CORROSION PROBLEMS
16	10	87	R	KEIHAN SILENCERS
8	1	86	R	SUPPLIER
8	11	85	R	ARMOUR MANUFACTURE - R90/6
8	11	85	R	KEIHAN - R65
13	9	85	R	S/S ALTERNATIVES
9	5	85	R	BRAKEWELL & GREEN SYSTEMS
14	2	79	R	BRAKEWELL & GREEN SYSTEMS
15	8	85	R	KEIHAN SYSTEM - R100T
<u>Unspecified</u>				
25	1	88	K	HEAT SHIELD DETERIORATION
12	8	87	K	HEAT SHIELD RATTLE
8	7	86	K	HEAT SHIELD RATTLE
14	12	85	K	HEAT SHIELD RATTLE
18	2	87	K	NOTAD SILENCER
9	3	86	K	NICO BAKEREXHAUSTS
10	12	87	R	CORROSION PROBLEMS
23	12	87	R	CORROSION PROBLEMS - PALLIATIVES
13	10	85	R	COPASLIF USAGE
8	1	85	R	OIL INJECTION FOR LONGER LIFE
15	4	83	R	SILENCER WARRANTY
14	12	81	R	PLATING COMPLAINTS
18	11	81	R	DUNSTALL SILENCERS

CLUTCH

PAGE MONTH YEAR TYPE

				<u>Clutch Splines</u>			
8	4	85	R	SHEARED SPLINES, R100			
8	4	85	R	SHEARED SPLINES, R60/6			
10	2	85	R	SHEARED SPLINES, R45			
15	10	83	R	SHEARED SPLINES, R65			
11	1	83	R	SHEARED SPLINES, R100RS			
				<u>Unspecified</u>			
8	7	86	K	CLUTCH CABLE, BROKEN			
10	12	87	R	CLUTCH RELEASE LUG BREAK, R90S			
15	10	87	R	CLUTCH RELEASE LUG BREAK, R90S			
10	12	87	R	THRUST BEARING WEAR			
8	9	86	R	EXCESSIVE CLUTCH WEAR & TOLERANCES, R100T			
13	7	86	R	CLUTCH REPLACEMENT, PROCEDURE			
18	3	86	R	<i>BORG & BECK</i> CLUTCH PLATES			
15	12	83	R	CLUTCH EXTRACTOR STUDS, THREAD SIZE			
13	7	83	R	THRUST BEARING, MISSING			
18	10	82	R	PRESSURE PLATE REMOVAL STUDS			
14	11	80	R	CLUTCH ASSEMBLY, R80GS			
23	7	79	R	CLUTCH REMOVAL			

GEARBOX BMWINDEX.006

PAGE MONTH YEAR TYPE

25	1	88	K	OIL LEAKS
7	11	87	R	END FLOAT & BEARING VARIANTS
21	6	85	R	END FLOAT, LAYSHAFT BEARINGS
10	2	85	R	GEARBOX SPLINES, SHEARING, R45
16	4	80	R	OIL MIGRATION, SHAFT TO GEARBOX, /7 MODELS
22	7	79	R	GEARBOX REMOVAL
11	3	79	R	KICKSTART FAILURE, R90/6
14	3	79	R	NOISE & LUBRICANTS

DRIVE SHAFT

PAGE MONTH YEAR TYPE

27	5	82		THEORY AND PRACTICE
24	4	82		THEORY AND PRACTICE
22	3	82		DRIVERS COMMENTS
12	11	79	R	SHOCK ABSORBING SHAFT, FITTING
17	6	79	R	VENTING AND FINAL DRIVE, MODS.
21	12	78	R	TORSION DAMPER, INTRODUCTION

FRONT FORKS

PAGE MONTH YEAR TYPE

				<u>Oil & Viscosity</u>			
32	2	87	K	CHANGE TO 155AE			
14	9	85	R	CORRECT REFILL, R45			
9	8	84	R	<i>CASTROL</i> BRAND			
16	4	80	R	OIL CHANGING, /7 MODELS			
				<u>Gaiters</u>			
26	1	88	K	REPLACEMENT			
11	8	85	R	FITTING			
23	6	85	R	FITTING			
20	4	85	R	DIFFICULTIES			
10	3	84	R	INSTALLATION			
				<u>Alternative Units</u>			
14	1	87	R	LEADING LINK FORKS, R80GS			
15	1	87	R	<i>WASP & SEBAC</i>			
16	7	79	R	<i>RDE</i> , LEADING LINK			
11	5	79	R	<i>Drs. RDE & THORPE</i> , UMIST, LEADING LINK FORK.			
8	9	76	R	<i>RDE & THORPE</i> FORKS			
22	7	79	R	EARLES FORK MAINTENANCE			

Unspecified

15	1	88	K	DAMPING KITS
7	7	85	R	FORK BRACE FITTING, R100T
7	6	85	R	HARD CHROMING OF FORK LEGS
14	2	85	R	DAMPING MODS., R80T '83
16	11	84	R	CLONKING NOISE, R100RS '80
13	4	82	R	CLONKING NOISE, R80/7 WITH RS FAIRING, MODS.
15	1	81	R	CLONKING SYMPTOMS, R80/7
17	11	84	R	STICKING FORKS, REMEDY
16	9	84	R	WHEEL INSTALLATION, CORRECT PROCESS.
20	4	82	R	FORKS, DETAILED DESCRIPTION & SERVICING.
14	2	77	R	MODIFICATIONS, /5 MODELS

STEERING

PAGE MONTH YEAR TYPE

11	2	85		HEAD BEARINGS, BRINELLING
14	11	84		HEAD BEARINGS, FITTING
16	7	84		HEAD BEARING, REMOVAL
18	7	84		HEAD BEARINGS, REMOVAL
22	6	84		HEAD BEARING, FRICTION ADJ.
11	10	87		HANDLEBAR CONVERSION, K75 FROM R80 '85
16	4	84	R	HEAD BEARINGS, R65
10	1	82	R	STEERING HEAD PRE-LOAD.

REAR WHEEL DRIVE AND SUSPENSION

PAGE MONTH YEAR TYPE

				<u>Suspension Units</u>			
8	5	86	K	<i>SPAX</i> , R100RS			
15	1	87	R	<i>SPAX</i> , R80GS			
6	12	82	R	<i>SPAX</i> , R80GS			
26	1	86	R	<i>M R HOLLAND</i> , AIR/COIL SPRING			
26	1	86	R	<i>M R HOLLAND</i> , MR MINDER UNIT			
11	6	85	R	<i>SEBAC</i> , UNITS			
12	5	85	R	INCORRECT SHOCK ABSORBERS, R100RS			
20	3	84	R	<i>SEBAC</i> PREVIEW			
14	12	82	R	NIVOMAT UNITS			
13	12	80	R	NIVOMAT, DESIGN DETAILS			
16	5	81	R	LIFE, R65			
13	3	81	R	<i>BOGE</i> AND <i>SAW</i> UNITS			
15	10	80	R	<i>SAW</i> ENGINEERED AIR BOOST			
10	2	79	R	<i>SAW</i> , DESCRIPTION			
11	6	79	R	AIR SUSPENSION, COMMENTS			
12	12	78	R	<i>SAW</i> INTRODUCTION			
12	5	77	R	FAILURE, R60/6			

BRAKES & PEDALS

PAGE MONTH YEAR TYPE

				<u>Brake Fluids</u>			
8	1	85		CONTAMINATION			
14	11	84		CONTAMINATION			
8	12	84		DETERIORATION			
12	10	84		TYPE & AVAILABILITY			
16	7	82		BRANDS			
14	4	82		BRANDS & SPECIFICATIONS			
19	4	82		BRANDS & SPECIFICATIONS			
				<u>Brake Pads</u>			
19	3	87		<i>FERODO</i>			
6	12	84		<i>MINTEX</i>			
16	8	84		ALTERNATIVE			
15	2	82		<i>LOCKHEED</i>			

Master Cylinder

25	1	88	K	SEAL REPLACEMENT
12	9	86	R	CRACKED CASTING, R90S
15	8	84	R	<i>DUCK OIL</i> , EASING
23	1	84	R	DIFFICULTIES, R100RS
19	8	83	R	RECONDITIONING
11	10	81	R	FRACTURE, <i>BREMBO</i> GUZZI PATTERN

Hoses

31	5	86	R	CHAFFING AT HOLDING CLAMP
7	1	86		<i>GOODRIDGE</i>
14	7	84		<i>GOODRIDGE</i> , BRAKE FADE

Unspecified

31	5	86	R	BRAKE LIGHT SWITCH STICKING
9	4	86	K	FRONT & REAR BRAKE SQUEAL
15	12	84	R	BRAKE SQUEAL, R100T
11	4	86	X	PADS STICKING IN CALIPERS
15	12	84	K	BRAKE COMPLAINTS

PAGE MONTH YEAR TYPE

				<u>Drive Splines</u>			
10	6	86	R	LUBRICANTS			
8	1	86	R	WEAR, R100RT			
13	1	85	R	<i>MOLYCOTE</i> BR2 LUBRICANT			
8	1	84	R	LUBRICANT			
22	1	84	R	LUBRICANT			
16	11	83	R	LUBRICANT			
19	9	83	R	LUBRICATION			
19	6	82	R	LUBRICATION			
24	5	82	R	WEAR ON R75/5, SEAL INTRODUCTION			
				<u>Unspecified</u>			
7	11	85	R	OIL LEVEL, R45			
14	9	85	R	LEAK TO BRAKE SHOES, R45			
17	7	85	R	DIL SEAL, R45 & 90/6			
19	11	84	R	LUBRICATION, SWINGING ARM BEARING			
14	5	83	R	DIL LEAKAGE, SWINGING ARM			
14	11	80	R	FINAL DRIVE, R80GS			

PAGE MONTH YEAR TYPE

22	9	87		BRAKING PERFORMANCE & COMPARISON
13	9	87	R	SLAVE CYLINDER REPAIR, R60/7
10	8	87	R	SHOE PULL-OFF SPRING FAILURE, NEW PATTERN
10	8	87	R	SHOE PULL-OFF SPRING, ANTI-VIBRATION RUBBER SLEEVE
11	2	85	R	PULL-OFF SPRING FAILURE, R80GS
21	1	87	R	REAR BRAKE FAILURE, TEMPORARY, <i>BRE</i>
31	5	86	R	PEDAL END-STOP MODIFICATION, R80
31	5	86	R	BRAKE BLEEDING
31	5	86	R	LINKAGE SEIZURE, REPAIR
7	7	85	R	DISC LINKAGE, PROBLEMS
22	5	85	R	STAINLESS STEEL REGRINDS
23	10	84	R	BRAKE FADE, PALLIATIVES
9	6	84	R	GRABBING, <i>FERODO</i> TREATMENT, R60/6
9	5	84	R	BRAKE DISC, HAIRLINE CRACKS
10	5	84	R	<i>CONTINENTAL</i> SUPER-TWINS, COMMENTS
20	4	84	R	INADEQUATE BRAKING, R100T
11	12	83	R	DRUM BRAKE PERFORMANCE & MAINTENANCE, R75/5
13	10	83	R	FRONT BRAKE EFFICIENCY
14	8	83	R	BRAKE BLEEDING
10	1	82	R	BRAKE BLEEDING, R65
12	10	79	R	REAR BRAKE SQUEAKING, R80/7
14	11	78	R	DRUM FRONT BRAKE ADJUSTMENT, /5
17	11	78	R	DRUM BRAKES, USEFUL HINTS
14	5	78	R	BRAKE LINING CHAMFERING
15	5	78	R	TWIN LEADING SHOE BRAKE ADJUSTMENT EARLES FORK MODELS
11	1	78	R	DRUM FRONT BRAKE, WHEEL LOCK,

WHEELS & TYRES

PAGE	MONTH	YEAR	TYPE	PAGE	MONTH	YEAR	TYPE
			<u>Wheels</u>	11	11	80	R
8	9	87	BEARINGS, SUPPLY	16	9	80	R
12	9	87	R BEARINGS, SUPPLY	13	6	80	R
13	7	87	R BEARING TOLERANCE, MoT QUERY, MONOLEVER MODELS	13	5	78	R
21	11	86	CAST WHEEL REPAIR SERVICE	11	4	78	R
12	2	85	R REAR SPLINES, LOOSE RIVETS	14	3	78	R
10	12	84	R CAST WHEEL REPLACEMENT	15	3	78	R
16	9	84	R FRONT WHEEL, CORRECT INSTALLATION	15	3	78	R
23	8	84	WHEEL RIM PROTECTORS				
13	7	84	R CAST WHEEL FAILURES, EXCHANGE	20	2	78	R
15	7	84	R BEARINGS, FITTING PROCEDURE				
14	5	84	R BEARINGS, CARE	15	1	78	R
12	7	83	R CAST WHEEL SPOKES	9	12	77	R
6	2	83	R FRONT WHEEL ALTERNATIVE, 80GS	12	11	77	R
18	12	82	R WIRE WHEELS v CAST WHEELS	6	12	76	R
22	12	82	R CAST WHEELS, APPROVAL & SAFETY				
16	10	82	R CAST WHEEL DAMAGE				
11	4	82	R CAST WHEEL, FAILURE				
14	2	82	R REAR WHEEL REMOVAL				
14	8	80	R REAR WHEEL REMOVAL				
			<u>Tyres</u>				
14	1	88	K PIRELLI RADIALS				
11	11	87	K PIRELLI RADIALS, FAILURE				
10	12	87	K MICHELIN RADIALS				
10	10	87	K VALVE BODY LEAKS				
14	10	87	K PIRELLI, DUNLOP & MICHELIN RADIALS				
27	7	87	K METZELER ME99, REAR TUBE				
8	11	86	K FITTING TUBES TO TUBELESS TYRES				
7	10	86	K ATS TYRE SUPPLIES				
8	4	86	K PIRELLI 'PHANTOM' USAGE				
9	3	86	K METZELER 'LAZER', FRONT TYRE				
32	2	86	K OKO TYRE SEALANT				
9	5	85	FITTING, USEFUL HINTS				
12	3	85	FITTING DIFFICULTIES				
12	7	85	K METZELER REPLACING PIRELLI				
10	12	87	R ULTRA LOW PROFILE				
12	9	87	R METZELER 'MARATHON' ME88				
13	9	87	R METZELER ME99, R60/17				
16	3	87	R AVDM AM20 & 21, R45/65				
9	5	85	R TYRES & WHEELS, ALTERNATIVES, 80GS				
6	3	84	R AVAILABILITY, 80GS				
8	1	85	R METZELER & CONTINENTAL, COMMENTS				
13	9	84	R CONTINENTAL TK44, COMMENTS				
9	8	84	R WEAR, CONTINENTAL PANTERA FAIRING				
10	6	84	R CONTINENTAL SUPER TWINS, COMMENTS				
13	4	84	R CONTINENTAL SUPER TWINS, EXPERIENCES				
25	4	84	R CONTINENTAL SUPER TWINS, EXPERIENCES				
20	8	83	R CONTINENTAL SUPER TWINS, TEST RESULTS				
10	10	81	R CONTINENTAL R60/2				
20	4	81	R DIMENSIONS & RATING CLASSIFICATIONS				
10	12	80	R METZELER ME77, UNSUITABLE FOR CAST R80/7 WHEELS				

FRAME

PAGE	MONTH	YEAR	TYPE	PAGE	MONTH	YEAR	TYPE
			<u>Seats</u>	22	11	83	
25	9	87	K MODIFICATION	17	12	82	R
22	1	88	PAN RESTORATION	13	11	78	R
8	11	86	R MODIFICATION, R80GS	12	8	78	R
21	11	86	REPAIR SERVICE	12	5	78	R
9	2	86	R MODIFICATION, R90/7				
15	12	85	R DISCOMFORT, R80RT	5	7	77	R
10	6	85	R REPLACEMENT, FRED TOLLEY	14	6	77	R
13	11	84	R MODIFICATION, R65				
12	9	84	R HEIGHT MODS, R65	13	3	77	R
17	10	83	R MODIFICATION, R80RT	15	3	77	R
15	11	81	R MODIFICATION, R100/7				
22	3	79	R MODIFICATION, R100/7				
14	2	79	R REPAIR SERVICE, SOURCE				
			<u>Side & Centre Stands</u>				
22	3	87	K POWERED CENTRE STAND, US ORIGIN				
20	11	86	K STAND PIVOTS				
9	4	86	SELF RETRACTING SIDE STANDS, LEGAL ASPECTS				
11	6	85	SIDE STAND, LEGISLATION				
15	12	85	K SIDE STAND FAILURE	25	1	88	K
11	10	85	K CENTRE STAND FAILURE	14	10	87	K
8	4	87	R SIDE STANDS, REFURBISHING	8	5	87	K
23	8	86	R SUREFOOT SIDE STAND, SUPPLIER	8	10	86	K
6	1	86	R SUREFOOT SIDE STAND	10	12	87	
8	1	86	R SIDE STAND COMPLAINTS, R100RT	9	12	86	
13	12	85	R SIDE STAND, R80RT	9	3	84	
14	12	85	R CENTRE STAND MODS.	14	11	82	R
9	11	85	R CENTRE STAND MODS, R65	17	7	82	R
20	16	85	R CENTRE STAND REDESIGN, R65				
11	8	85	R SIDE STAND, MODS, R80RT	18	6	82	R
13	8	86	R CENTRE STAND MODS	18	10	81	R
7	6	85	R CENTRE STAND MODS	8	3	77	R
7	6	85	R SUREFOOT LIMITATIONS				
10	5	85	R CENTRE STAND MODS.				
20	3	85	R CENTRE STAND MODS.				
8	1	85	R CENTRE STAND PROBLEMS, R100RS				
17	2	83	R CENTRE STAND MODS.				
14	2	83	R CENTRE STAND MODS.				
18	12	82	R CENTRE STAND, REPAIR R80/7				
29	12	82	R SIDE STAND, 800 PORECHA				
21	9	82	R CENTRE STAND, FAILURE R100 '82				
13	2	82	R BATES STAND, SELF RETRACTING				
13	12	81	R BATES, FATIGUE CRACK				
17	12	81	R CENTRE STAND TROUBLES				
6	10	76	R CENTRE & SIDE STAND DIFFICULTIES				
			<u>Unclassified</u>				
25	1	88	K TAIL SECTION, RESPRAYED				
7	6	86	K RUST PROBLEMS				
9	12	87	PAINTING SERVICE				
9	11	87	SUSPENSION THEORY				
16	11	87	SUSPENSION THEORY				
9	11	86	FRAME STRAIGHTENING, SERVICE				
14	12	85	R STAINLESS STEEL GRABRAIL, 16 & 17				
12	9	84	R RUSTING TREATMENT				

ROAD TESTS, RIDING EXPERIENCES
& NEW MODELS

PAGE	MONTH	YEAR	TYPE	
<u>New Models</u>				
19	9	87	K	MASTER DESIGN STUDY, K100
15	9	87	K	SPECIAL EDITION FEATURES, K100RS
7	6	87	K	K 100LT
19	6	87	K	DEALER 'RIDEAWAY', K75S
14	9	86	K	INTRODUCTION, K75S
20	2	86	K	INTRODUCTION, K75
32	2	86	K	IMPROVEMENTS, K100
19	3	84	K	DETAILED DRAWINGS, K100
9	11	83	K	LAUNCH, K100
14	8	85	R	SAN JOSE SPORTPAC ST SPECIAL
16	8	85	R	1985 MODELS
18	5	85	R	1985 MODEL LAUNCH
20	2	83	R	R80ST, PRE-VIEW COMMENT
26	12	80	R	FUTURE DESIGN EXERCISE
12	10	80	R	AVIGNON LAUNCH, R80GS
2	10	79	R	NEW MODEL TRENDS, WATER COOLED 3 & 4 CYLINDER ENGINES
21	11	78	R	COLOGNE SHOW MODEL LINE UP '79
14	10	77	R	POWER UNIT DETAIL, R80/7
7	11	76	R	MODEL RANGE, '76/'77
8	12	76	R	INTRODUCTION, 100RS & 7 RANGE
10	11	76	R	R75/5, DAHNE CONVERSION
<u>Road Tests</u>				
14	12	87		K75RT, COMMENTS
12	6	86		K75RS, EVALUATION
14	6	84		K100, COMMENTS
23	9	83		R80ST, TOURING TEST
24	11	82		R80RT, ROAD IMPRESSIONS & TECHNICALITIES
14	8	81		R100RT, RE-TEST WITH NIVOMATS
14	3	80		R100RT, ROAD TEST & FACTORY VISIT
14	10	78		R51, '38 MODEL
19	6	78		R100S, COMPARISON WITH /6 & /7 MODELS
14	2	78		R80/7, TEST
7	1	77		R100RS, TEST
<u>Riding Experiences</u>				
22	8	87		K VERSUS R
16	5	87		K100RT v R100RT
26	5	87		K TO R
17	4	87		K 75, OWNERS EXPERIENCE
24	2	87		HEDINGHAM SIDECAR
20	10	86		COMPARISON WITH NORTON WANKEL
18	7	85		K75, LONG DISTANCE RUN
10	4	86		K75, RIDING COMMENTS
11	4	86		K100RS, USER EXPERIENCE & PROBLEMS
16	10	85		K75, INTRODUCTION
18	6	85		K100RT v R100RT
7	4	85		K100, PILLION RIDER'S COMMENTS
22	4	85		K100RT, RIDING EXPERIENCES
7	2	85		K100RT, PILLION RIDER'S COMMENTS
14	12	84		K100, UPDATE, USA6E & COMPLAINTS

PAGE	MONTH	YEAR	TYPE	
20	11	84		K v RS, COMPARISON
9	11	87		R80GS, RIDING EXPERIENCES
9	11	87		R100RS, RIDING EXPERIENCES
14	11	87		R80, PATROLMAN'S TALE
16	10	87		R80GS, RIDING EXPERIENCES
16	8	87		R80GS, DESERT TOURER MOOS.
24	8	87		R80, IN DEFENSE
16	6	87		R80RT, A COURIER'S TALE
9	10	86		R100RT, WINDSCREEN TRIM
14	6	86		R90RS, EXPERIENCES
17	3	86		R80, WITH SPRINT FAIRING
13	2	86		R75/6, USER COMMENTS
11	5	85		R65, VIBRATION
14	5	85		SQUIRE SIDECAR, TYPE D18
14	9	84		STAR RIDER QUALIFICATION
8	7	84		/7 & KR5 RIDER IMPRESSIONS
20	6	84		R80GS, RIDING EXPERIENCES
16	5	84		R80, EX POLICE MODEL
22	5	84		R65, & WATSONIAN SIDECAR
15	4	84		HEIDENHAG & KRAUTER SIDECAR, BMW APPROVED
12	1	84		MAUDES TROPHY, R75/5
16	1	84		NURBURGRING 1983
8	10	83		JIM KENTISH, RIDING EXPERIENCES
8	9	83		JIM KENTISH, RIDING EXPERIENCES
12	9	83		R65, COMMENTS
12	9	83		R80ST, RIDING COMMENTS
17	8	83		R100, RIDING COMMENTS
18	8	83		R100/7, RIDING COMMENTS
17	5	83		R80/7, RIDING COMMENTS
25	5	83		R80ST, RIDING COMMENTS
18	3	83		R100RS, RIDING COMMENTS & PROBLEMS
17	2	83		R100RS, RIDING COMMENTS
9	1	83		R100RT, 16000 MILE APPRAISAL
14	1	83		R65LS, RIDING IMPRESSIONS
18	1	83		R100RS, MOTORSPORT, EXPERIENCES
17	2	82		R100RS, USER EXPERIENCES
26	12	82		R60/6, 100000 MILE ACCCUNT
26	10	82		R65LS, EXPERIENCES
25	9	82		R65, EXPERIENCES
21	8	82		R50, EXPERIENCES
20	6	82		R75/6, COMPREHENSIVE COMMENTS
12	3	82		R45, EXPERIENCES
13	2	82		R100RS, EXPERIENCES & COMPLAINTS
22	1	82		NURBURGRING TRAINING COURSE
24	12	81		HUB CENTRE SPECIAL
13	11	81		R100, EXPERIENCES
26	9	81		MARATHON 'END TO END'
15	8	81		R100RT, EXPERIENCES
9	4	81		R45, EXPERIENCES
10	7	81		R45, EXPERIENCES
10	7	81		R65, VIBRATION

PAGE	MONTH	YEAR	
11	7	81	R65, VIBRATION & ADJUSTMENTS
18	5	81	R60/6, EXPERIENCE
10	4	81	MMK 1000 SPECIAL
14	4	81	R80, RIDING EXPERIENCES
14	12	80	'WALKER BULLPUP' SPECIAL
20	11	80	POLICE MACHINES AT WORK
9	10	80	HONDA CBX v BMW
18	10	80	FUEL CONSUMPTION, SURVEY
10	2	80	DUTCH POLICE, RIDING WITH THEM
16	2	80	R65, EXPERIENCES
20	2	80	1955-'69, IGNITION, GEARBOX & CLUTCH ASPECTS
20	1	80	R100/7 SPECIAL
9	3	79	R100/7 & PALMA SIDECAR
9	2	78	FALLERT MOTOR
9	11	78	R80GS MOOS.
8	9	78	R90/6, SAFARI MOOS.
10	10	78	RS4/6S, DIFFERENCES FROM /7
13	9	78	R75/7, OWNERS' COMMENTS
18	9	78	NURBURGRING TRAINING COURSE
9	8	78	R45, APPRAISAL
18	4	78	R60/7 TOURING IN IRELAND
7	3	78	R60/7 TOURING IN IRELAND
15	11	77	R75/5, EXPERIENCES
9	10	77	R100RS, EXPERIENCES
5	3	76	R75/5, EXPERIENCES

**CLOTHING, PROTECTIVE GEAR,
LUGGAGE & ACCESSORIES**

PAGE	MONTH	YEAR	PAGE	MONTH	YEAR	
			23	12	80	<i>RAIN X WATER DISPERSANT</i>
35	1	88	23	12	80	<i>VARI-CLEAR ANTI MIST AGENT</i>
15	10	87	12	7	80	<i>BOB HEATH 'UVEX' GLASS VISORS, DIFFICULTIES</i>
27	5	87				<i>BOB HEATH 'UVEX' VISORS</i>
12	8	86	12	5	80	Luggage
12	7	80				<i>REMOVAL PANNIER BAGS</i>
7	7	86	11	10	87	<i>HARD TANK BAGS</i>
6	10	85	17	2	87	<i>BMW TANK BAGS</i>
6	10	85	26	2	86	<i>PANNIER BOX LOCKS, WEAR</i>
21	10	85	8	3	86	<i>RS FAIRING BAGS, SOURCE</i>
22	11	84	9	5	84	<i>PORECHA FAIRING BAGS</i>
8	6	84	17	4	84	<i>ALLIGATOR TANK BAG</i>
13	3	81	11	10	79	<i>KRAUSER LUGGAGE, PARTS</i>
20	4	84	16	7	79	<i>COMPREHENSIVE LUGGAGE SURVEY</i>
22	4	84	18	12	78	<i>BMW LUGGAGE</i>
25	12	82	19	11	78	<i>KRAUSER SECURITY STRAPS</i>
21	7	81	17	10	78	<i>USER COMMENTS</i>
18	11	82	20	9	78	<i>LUGGAGE SURVEY</i>
22	11	81	13	8	78	<i>LUGGAGE SURVEY</i>
20	5	81	7	7	78	<i>LUGGAGE SURVEY</i>
28	10	82	13	6	78	<i>LUGGAGE SURVEY</i>
28	8	81	6	12	76	<i>SWAGMAN TANK BAGS</i>
24	3	80	2	1	76	<i>KRAUSER PANNIERS, SECURITY</i>
20	7	79				Accessories
12	5	79	6	1	88	<i>INSTANT AIR KIT</i>
14	5	79	12	5	87	<i>K SERIES, STAINLESS RAD. GRILL</i>
			11	2	87	<i>K SERIES, HEATED GRIPS</i>
			21	1	87	<i>FM RADIO, R100RT</i>
			9	12	86	<i>SONIC INTERCOM SYSTEM</i>
14	5	79	15	9	85	<i>SONIC INTERCOM, FITTING</i>
16	5	79	10	10	86	<i>BMW INTERCOM</i>
14	3	79	10	3	86	<i>HUIJSH LEG SHIELDS</i>
			12	9	85	<i>HALFORDS CLOCK & VOLTMETER</i>
18	2	79	13	7	85	<i>AUXILIARY LAMPS, R100RT FITTING</i>
			29	7	85	<i>TOW BAR, R SERIES</i>
			21	3	85	<i>IGNITION LOCK, DIGITAL, DESIGN</i>
			8	11	84	<i>HEATED GRIPS</i>
15	1	88	17	4	84	<i>HEATED GRIPS, R65, FITTING</i>
24	12	87	11	6	84	<i>FUEL INJECTOR COVER, K SERIES</i>
16	9	87	17	3	84	<i>FUEL TANKS, 7 1/2 GALLON, SUPPLIER</i>
21	8	87	24	2	83	<i>REGENCY LEG SHIELDS</i>
10	9	86	25	1	83	<i>SINGLE SEAT CONVERSION, R100RS</i>
10	5	85	23	9	82	<i>BMW 'SUPER TOOL KIT'</i>
11	3	85	23	9	82	<i>BMW PORTABLE PLUG-IN LIGHT</i>
6	12	84	16	6	82	<i>MASTERMAN ALARM</i>
			11	1	82	<i>BMW INTERCOM SYSTEM</i>
14	7	83	24	9	81	<i>BMW 'SUPER TOOL KIT', HAND LAMP, HEATED GRIPS & SILENCER SHIELD</i>
19	5	83				<i>BMW FAIRING KIT</i>
19	4	83	21	7	81	<i>DIL CODLER FITTING TO R 90S</i>
14	2	83	22	11	80	<i>STADIUM SILVER CROSS & UVEX GOGGLES</i>
19	12	82	24	6	80	<i>ACCESSORY RELAYS, FITTING</i>
13	9	81				<i>UVEX & OCTOPUS GP GOGGLES</i>
15	5	81	8	11	79	<i>BMW MULTI PURPOSE ACCESSORY LAMP</i>
16	2	81	9	8	79	<i>BMW RADIO & INTERCOM SYSTEM</i>
			21	12	78	
			21	12	78	

INSURANCE

PAGE	MONTH	YEAR	
8	12	87	<i>BEACON MOTOR SYNDICATE</i>
11	9	87	<i>BEACON MOTOR SYNDICATE</i>
10	12	87	<i>NORWICH UNION</i>
10	12	87	<i>DIRECT INSURANCE SERVICES (DIS)</i>
9	12	86	<i>DIS, USER RATING</i>
11	10	86	<i>DIS & CO-OP, COMPARISONS</i>
12	10	85	<i>DIS/BMF CLAIM REPORT</i>
12	9	85	<i>DIS/BMF PREMIUMS</i>
12	8	85	<i>DIS/BMF PREMIUMS</i>
17	9	83	<i>DIS/BMF PREMIUMS</i>
20	12	82	<i>DIS/EAGLE STAR/ LOMBARD, COMPARISONS</i>
18	5	82	<i>DIS/BMF REVIEW</i>
15	5	81	<i>DIS/BMF, NORWICH UNION, COMMENTS</i>
12	8	80	<i>DIS/BMF, NORWICH UNION, COMMENTS</i>
11	5	80	<i>DIS/BMF, AT LLOYDS</i>
3	9	79	<i>BMF INSURANCE SCHEME LAUNCH</i>
8	12	86	<i>CO-OP INSURANCE SOCIETY</i>
10	9	86	<i>BMW SYSTEM HELMETS, INSURANCE LIABILITY</i>
13	12	85	<i>AA & NORWICH UNION PREMIUMS</i>
12	10	85	<i>COMMERCIAL UNION PREMIUMS</i>
12	7	85	<i>VINTAGE/CLASSIC INSURANCE</i>
10	5	85	<i>NATIONAL INSURANCE POLICIES</i>
9	3	85	<i>NATIONAL INSURANCE POLICIES</i>
22	11	84	<i>NATIONAL BREAKDOWN RECOVERY CLUB (IAM SCHEME)</i>
23	9	82	<i>EUROPE ASSISTANCE, SATISFACTION</i>
11	3	82	<i>EUROPE ASSISTANCE, SATISFACTION</i>
17	7	82	<i>BMF, BMW, CO-OP PREMIUMS</i>
14	6	82	<i>KNOCK FOR KNOCK CLAIM SETTLEMENT</i>
16	5	81	<i>BA INSURANCE BROKERS</i>
14	3	81	<i>PREMIUMS, YOUNG RIDERS</i>
11	12	80	<i>NORWICH, BRADFORD PENNINE, BEDALL BRADFORD PREMIUMS</i>
19	7	79	<i>IAM INSURANCE REBATE</i>
19	7	79	<i>PRUDENTIAL, CSMA, RATES</i>

RACING

PAGE	MONTH	YEAR	
24	11	87	<i>GOODWOOD '87</i>
15	8	87	<i>CADWELL PARK, MAY '87</i>
15	8	87	<i>DAVE BARRETT, PROFILE</i>
24	6	87	<i>GOODWOOD TRACK DAY</i>
17	12	86	<i>LE MANS '86</i>
23	11	86	<i>CADWELL PARK</i>
13	9	86	<i>IOM REPORT</i>
12	4	86	<i>IOM</i>
10	8	85	<i>K100RS, RACING EXPLOITS</i>
20	6	85	<i>GOODWOOD, GUILDFORD SECTION</i>
20	7	83	<i>MIKE TISSALL</i>
8	5	83	<i>DAVE CROFT, SPORTING SPIRIT TROPHY</i>
21	11	82	<i>R69S, MONTHLEHERY RECORDS</i>
22	11	82	<i>LYDDEN</i>
13	1	82	<i>CADWELL PARK, RACING LINES</i>
24	11	81	<i>CADWELL PARK, VCC MEETING</i>
22	11	81	<i>RACING NOSTALGIA, JOCK WEST</i>
24	12	80	<i>RACING NOSTALGIA, JOCK WEST</i>
24	9	80	<i>LYDDEN, HIGH SPEED TRIALS</i>
12	3	80	<i>BMWCS, FIXTURES</i>
14	11	79	<i>TRIUMPH OWNERS CLUB, LYDDEN & BRANDS HATCH</i>
10	7	79	<i>TRIUMPH OWNERS CLUB, LYDDEN</i>
10	7	79	<i>VELOCETTE OWNERS CLUB, CADWELL</i>
14	6	79	<i>RS1 in 1939 TT</i>
10	11	77	<i>BOL D'OR 24 HOURS, MEMBER'S ACCOUNT</i>
10	6	77	<i>'77 GUS KUHN ENDURANCE RACER</i>
13	5	77	<i>RACING SIOECAR OUTFITS</i>
9	9	76	<i>BELGIAN GRAND PRIX</i>
4	7	76	<i>IOM TT</i>
5	7	75	<i>BMW RACING MACHINES</i>

TOURING

PAGE	MONTH	YEAR		PAGE	MONTH	YEAR	
<u>United Kingdom</u>							
26	5	87	WORCESTERSHIRE RUN	13	2	87	ISRAEL, PROPOSED IMTC TRIP
15	2	87	LAKELAND PASSES	16	9	86	EGYPT
19	2	87	DORSET DELIGHTS	17	6	86	TURKEY
23	5	86	CHRISTMAS JOURNEY				
16	1	85	CLEETHORPES, REVIEW	<u>Far East</u>			
17	6	84	SEATOM, NATIONAL EVENT	20	10	81	INDIA
22	5	81	ARRAN TOURING	16	11	80	NEPAL
24	5	81	SCOTLAND	<u>Australia & New Zealand</u>			
20	10	78	SCOTTISH HIGHLANDS	23	4	87	AUSTRALIA, ANTIPODEAN HIGHWAY
6	2	77	END TO END	24	4	85	AUSTRALIA
3	11	76	SCOTLAND, A TOURING WEEKEND (1)	10	5	81	WESTERN AUSTRALIA
4	10	76	SCOTLAND, A TOURING WEEKEND (2)	11	5	81	TASMANIA
6	8	76	WEST COUNTRY JAUNT, EASTER	18	4	81	NEW ZEALAND
<u>Continent</u>							
18	1	88	FRANCE, C'EST LA VIE	14	9	77	EASTERN AUSTRALIA
12	12	87	RUSSIA, VIA TO FILM RALLY	6	7	76	SOUTHERN CROSS ROAD, TRACK TO ALS.
11	11	87	AUTOBAHN SERVICE BOOKLET	<u>Africa</u>			
19	12	87	GERMANY, THE OTHER SIDE OF THE ROAD	16	1	87	MOROCCO, TOURING IN THE SUN
21	4	87	BRITANNY, LONDON SECTION	20	6	79	MOROCCO
26	4	87	GERMANY, JUST A BIT OF FUN	16	7	85	AFRICA, EXPLOITS
10	3	87	NORDKAPP	10	4	85	SAHARA
6	12	86	COLLINS BIKE TOURS	18	3	85	SAHARA
9	10	86	INT. MOTORCYCLISTS TOUR CLUB	15	2	85	SAHARA
17	6	86	TURKEY	20	5	84	SOUTH AFRICAN DIARY
18	4	86	TOURING EXPERIENCES	18	12	82	SOUTH AFRICAN DIARY
14	1	86	GREECE BY KIOORT	19	12	80	SOUTH AFRICAN DIARY
24	1	86	DENMARK, EA SECTION VISIT	21	9	80	SOUTH AFRICAN DIARY
16	12	85	GERMANY	20	12	79	SOUTH AFRICAN DIARY
7	11	85	GERMANY BY RIDORS	16	10	79	SOUTH AFRICAN DIARY
14	11	85	SCANDINAVIA	20	4	79	SOUTH AFRICAN DIARY
22	9	85	PORTUGAL	10	8	78	SOUTH AFRICAN DIARY
23	5	85	TOURING IN EUROPE BOOK	12	8	78	SOUTH AFRICAN DIARY
16	1	85	BEAUJOLAIS NOUVEU RUN	18	12	77	SOUTH AFRICAN DIARY
10	8	84	BERLIN, FACTORY VISIT	12	10	77	SOUTH AFRICAN DIARY
8	7	83	NORWAY & ARCTIC CIRCLE	18	9	77	SOUTH AFRICAN DIARY
12	5	82	CONTINENTAL TOURING	9	1	77	SOUTH AFRICAN DIARY
16	5	82	SWEDEN	<u>USA & Canada</u>			
16	3	82	EAST GERMANY	25	10	87	CARDL BONSON, BMWDA RETIREMENT
12	6	81	FINLAND TRAVELOGUE	25	4	87	TOURING '86
19	1	81	CONTINENTAL TOURING	12	12	86	AMERICA HERE WE COME
18	1	81	CONTINENTAL TOURING, 5 COUNTRIES	20	9	85	USA
15	10	80	SPAIN TRAVELOGUE	9	7	85	USA
22	7	80	TURKEY	12	1	85	USA
16	5	80	SOUTH OF FRANCE	16	2	84	BRITISH COLUMBIA
18	5	79	ITALY, GAVIA PASS	16	4	79	US STYLE TOURING
14	2	78	ALPINE PASSES	22	8	78	USA, PRESIDENT'S ACCOUNT
16	8	78	YUGOSLAVIA/ ALBANIA	8	2	78	BMWDA EVENTS, PART 3
16	8	78	NORWAY, SWEDEN, FINLAND	14	1	78	BMWDA EVENTS, PART 2
16	7	77	EASTERN GERMANY, PART 4	20	12	77	BMWDA EVENTS, PART 1
16	6	77	EUROPE REVISITED, PART 3				
9	5	77	EUROPE REVISITED, PART 2				
16	4	77	EUROPE REVISITED, PART 1				
6	6	76	BERLIN, SPANOAU VISIT				

VINTAGE & VETERAN

PAGE	MONTH	YEAR		PAGE	MONTH	YEAR	
<u>Other Countries</u>							
13	11	86	ANTIPODES, EASTER	8	10	86	R50 MODEL, CLUB POPULATION
21	4	86	CORSICA	23	10	86	VMCC FOUNDERS DAY & TECHNICAL INFORMATION
20	8	85	CRETE	21	9	86	INSTRUCTION MANUALS, PARTS LISTS, DIAGRAMS
13	3	84	SICILY	6	1	85	OFFENBACH MUSEUM, VISIT
17	6	80	WORLD TOUR PLANNING	18	2	84	R10, MODEL DESCRIPTION
14	10	79	IRISH REPUBLIC	19	12	83	INTERNATIONAL CLASSIC BIKE SHOW
16	6	78	ICELAND	5	8	83	BMW BOXER TWINS, 60 YEARS
18	5	78	ICELAND	16	2	82	IN SEARCH OF BMW, HISTORY
18	4	78	IRELAND WITH R60/7	9	1	81	IN SEARCH OF BMW
7	3	78	IRELAND WITH R60/7	26	10	80	IN SEARCH OF BMW, RS1/2
5	9	76	IRISH REPUBLIC	20	9	81	IN SEARCH OF BMW, PRODUCTION AT EISENACH
<u>Unspecified</u>							
8	9	87	FALK MAPS	24	8	81	IN SEARCH OF BMW
19	8	87	TOURING HINTS	23	6	81	IN SEARCH OF BMW, RACING
9	12	84	CREDIT CARDS, USE ABOARD	26	5	81	IN SEARCH OF BMW, DRIVE TORQUE REACTION
6	11	76	KRAUMETZ SDS, BREAKDOWN SERVICE	20	2	81	IN SEARCH OF BMW
3	6	76	TOURING HINTS	24	11	80	IN SEARCH OF BMW
<u>BMW Models</u>							
26	10	80	IN SEARCH OF BMW, SUPERCHARGERS IN THE ISLAND(TT)	26	9	80	IN SEARCH OF BMW, MODEL REVIEW
16	8	80	IN SEARCH OF BMW, R23	16	8	80	IN SEARCH OF BMW, R23
16	7	80	IN SEARCH OF BMW, R66	20	6	80	IN SEARCH OF BMW, R5
18	5	80	IN SEARCH OF BMW, R12	18	5	80	IN SEARCH OF BMW, R12
22	4	80	IN SEARCH OF BMW, R16	22	4	80	IN SEARCH OF BMW, R16
22	3	80	IN SEARCH OF BMW, 1936 - 38	22	3	80	IN SEARCH OF BMW, 1936 - 38
22	1	80	IN SEARCH OF BMW, R5 & R51	22	1	80	IN SEARCH OF BMW, R5 & R51
22	12	79	IN SEARCH OF BMW, R12	22	12	79	IN SEARCH OF BMW, R12
18	10	79	IN SEARCH OF BMW, R3 & R4	18	10	79	IN SEARCH OF BMW, R3 & R4
22	9	79	IN SEARCH OF BMW, R62, R63, R11 & R16	22	9	79	IN SEARCH OF BMW, R62, R63, R11 & R16
18	8	79	IN SEARCH OF BMW, R37, R42 & R32	18	8	79	IN SEARCH OF BMW, R37, R42 & R32
24	7	79	IN SEARCH OF BMW, 1916 PERIOD, R32	24	7	79	IN SEARCH OF BMW, 1916 PERIOD, R32
18	6	79	IN SEARCH OF BMW, 1915 ONWARDS	18	6	79	IN SEARCH OF BMW, 1915 ONWARDS
9	6	78	R12 - 1935	9	6	78	R12 - 1935
8	5	78	R12 - 1935	8	5	78	R12 - 1935
14	4	78	492cc RACING ENGINE, 1954	14	4	78	492cc RACING ENGINE, 1954
10	3	78	492cc BOXER, 1954	10	3	78	492cc BOXER, 1954
16	12	77	'GEAR' LEVER ON PRE-'54 MODELS	16	12	77	'GEAR' LEVER ON PRE-'54 MODELS
11	10	77	R5 REMINISCENCES	11	10	77	R5 REMINISCENCES
18	10	77	R51 REBUILT	18	10	77	R51 REBUILT
8	9	77	INTRO. OF BMW TO UK MARKET, 1930	8	9	77	INTRO. OF BMW TO UK MARKET, 1930
9	7	77	LOOKING BACK	9	7	77	LOOKING BACK
8	6	77	LOOKING BACK	8	6	77	LOOKING BACK
10	5	77	BMW NOSTALGIA, 1944, TORRENS	10	5	77	BMW NOSTALGIA, 1944, TORRENS
15	5	77	PUBLICATIONS & LITERATURE	15	5	77	PUBLICATIONS & LITERATURE
3	3	76	R27, HISTORY OF REBUILD	3	3	76	R27, HISTORY OF REBUILD

PAGE MONTH YEAR

EIA			
22	12	87	1988, SW SECTION TO FINLAND
18	11	87	1987, SW SECTION, FRANCE
25	2	87	1986, MOTOCAMP
11	11	86	1986, BUDAPEST
12	10	86	1986, SW SECTION REPORT
17	9	85	1985, GERMANY
24	10	84	1984, SWEDEN
24	10	83	1983, AUSTRIA
6	8	82	1982, SWITZERLAND
18	9	81	1981, YUGOSLAVIA
20	8	79	1978, ITALY

Krauser			
22	5	87	TAKE THREE GIRLS
21	10	86	1985, REPORT
14	4	85	1984, report

BME Rally			
7	10	86	MILEAGE DISCREPANCIES
26	7	82	REPORT
14	7	79	REPORT
11	8	78	REPORT

Others			
15	9	87	MAKE A DATE IN '88, CLUB EVNETS
15	8	87	ELEPHANT & SOUTH AFRICA
9	6	87	CLUB NATIONAL, EXMOUTH
24	1	87	EA SECTION, SUMPSCRATCHERS
20	12	86	KRYSTALL, NORWAY, REPORT
18	11	86	MCC LANDS END
18	10	86	SAXMUNDHAM, CLUB INTERNATIONAL
31	9	86	CLUB NATIONAL, EXMOUTH
20	7	86	CLUB, ULSTER RALLY
22	1	86	EA SECTION, SUMPSCRATCHERS
18	10	85	BMW CLUBS EUROPA, TRENTHAM GARDENS
14	8	85	CLUB, BLAIR ATHOLL
23	8	85	BMW CLUBS EUROPA RALLY, GARMISCH-PARTENKIRCHEN
11	7	85	CLUB, 'GOSSIES' TREASURE HUNT
14	6	85	NATIONAL, CLEETHORPES
16	5	85	ELEPHANTEN
13	12	84	CLUB, SAXMUNDHAM, REPORT
20	12	84	CLUB, DIRTY WEEKEND
18	10	84	BMW CLUB EUROPA, LONGLEAT
28	10	84	CLUB, WENTNOR
17	8	84	CLUB, BLAIR ATHOLL
10	7	84	CLUB, ULSTER RALLY
18	4	84	YORKSHIRE SECTION, ALPINE RUN
31	4	84	BMW CLUBS EUROPA RALLY, MERANO, ITALY
16	3	84	PARIS-DAKAR, 4th
24	10	83	BMW, 60TH ANNIVERSARY, MUNICH
22	1	83	EA SECTION, SUMPSCRATCHERS
23	12	82	EAST ANGLIAN TROPHY
21	10	82	BMW CLUBS EUROPA INTERNATIONAL
27	9	82	BEAUJOLAIS RUN

PAGE MONTH YEAR

29	10	81	BMWQA, TENNESSEE
18	6	81	PARIS-DAKAR, 3RD
20	9	79	CLUB INTERNATIONAL, SAXMUNDHAM
16	2	79	INT. DES ALPES, 1978
20	7	79	IRISH RALLY
10	11	78	CLUB INTERNATIONAL, SAXMUNDHAM
7	3	77	STELLA ALPINA
4	8	76	CLUB INTERNATIONAL, 10th ASSEMBLY
4	4	76	21ST ELEPHANT RALLY

TRIALS

PAGE MONTH YEAR

13	3	87	MCC, LANDS END '87
17	8	86	LAND ACCESS FOR EVENTS
10	11	85	MCC, LANDS END '85
18	4	85	PARIS-DAKAR
20	7	84	MCC, LANDS END '84
16	12	80	MCC, EDINBURGH TRIAL
9	4	80	ISDE, BMW TEAM
15	1	80	ISDE, REPORT
10	1	79	MCC, EDINBURGH TRIAL '78
13	4	78	MCC, EXETER TRIAL
18	2	78	MCC, EDINBURGH TRIAL '77
10	3	77	MCC, EXETER TRIAL '77
6	8	76	MCC, EXETER TRIAL '76
5	1	76	MCC, EDINBURGH TRIAL

SIDECARS

PAGE MONTH YEAR

11	6	85	STEIG SIDECAR AVAILABILITY
10	10	79	STEIG, COMMENTS
20	3	79	STEIG, DEVELOPMENTS 1983
8	11	77	STEIG, R60/6, R75/6,
14	8	85	SQUIRE SIDECAR Type D18
22	5	84	R65 & WATSONIAN
15	4	84	HEIDENWAG & KRAUTER
14	1	81	SIDECAR OUTFIT, MIXED PARENTAGE
21	7	80	ENL, REVIEW
12	1	80	WOOD SPECIAL
10	12	79	WATSONIAN PALMA WITH R75/6

Non-Current Parts & Spares

The nature of BMW motor cycles is that they remain in day to day use for longer than most other contemporary machines and new models regularly feature components which are common to earlier models. Consequently the demand for spares remains for longer. Legislation in Germany demands that parts remain readily available from the manufacturers for at least 10 years following cessation of manufacture of any model. Consequently spares availability through the dealer network for models up to ten years old should in theory be no problem. Beyond ten years the problem of obtaining parts is an increasing one.

The addresses below are likely sources of BMW parts, and specialist services, especially useful to owners of pre /5 machines (1969). However, we expect that some of those listed will now be dealing in /5 and /6 machine parts also.

BMW tell us that in theory some components for many older machines are still available on order through the dealer network. However general experience is that franchised dealers don't test the system very enthusiastically. Except, that is, for a few notable exceptions, such as Gus Kuhn (Clapham, S. London), Slocombes (Neasden, N. London), and Jefferies (Shipley, Yorkshire).

IF ANY MEMBERS DISCOVER ANY NEW SOURCES PLEASE LET THE CLUB VINTAGE SECRETARY KNOW. HE WILL UPDATE THE LISTING AND LET OTHER MEMBERS KNOW ABOUT THEM THROUGH THE JOURNAL.

BMW PARTS

United Kingdom

Bob Porecha, 303 Sydenham Road, London. Phone 01.659.8860
Markhouse Motorcycles, 109 Markhouse Rd., Walthamstow, London E7. Tel 01.520.1754

Dave Dickinson, Crawny House, Killane, Ballaugh, Isle of Man. Phone 0624.897731
Motobins, 16 Headley Road, Woodley, Reading, Berks RG5 4JA. Phone 0734 696532
Classic Restorations, 10 Linicro Kilmuir, Portree, Isle of Skye. Tel: 047.042.227
Phone 091.267.9869
Bracken Motorcycle Workshop, 330 St James Road, London SE1. Phone 01.231.9438

Other Countries

BMW Motorrad GmbH, Hufelandstr. 8, 8000 Munchen 40, W Germany. Phone 089.381081
Schorsch Meier GmbH, Daimlerstr. 21, 8046 Garching, W Germany. Phone 089.3201086
Motorrad Jaeger, Ehscheider Pfad 7-8, 5455 Bonfeld, W Germany. Phone 02634.1312/4
Ondrak, Echingerstr.4, 8056 Neufahrn, W Germany. Phone 089.325428
Helmut Bauer, Eberwurzstr.29, 8000 Munchen 45, W Germany. Phone 089.351117
A. Zeh, Welzheimerstr.29, 706 Schorndorf, W Germany. Phone 07181.76772
Josef Buchner, Freidbichlerstr.4, 8312 Dinggolfing, Postfach 1422, W Germany. Phone 08731.4987, 3562
Motorrad Stemler, Garschager Heide 29, 5630 Remscheid 11, Luttringhausen, W Germany. Phone 02191.50639
Ulli's Motorrad Laden, 6000 Frankfurt, Gutleutstr.74, W Germany.
Rocketship Spares, D6301 Rodheim/Biebertac, Hof Schmitte, W Germany
Ulrich Seiwert, Gutleustr.144, 6000 Frankfurt 1, W Germany. Phone 0611.233840
Studemann GmbH, Thomas Mann Str.31, 2000 Hamburg 71, W Germany. Phone 040.6404329
REKA Reno Kassmann, Seggeweg 8, 2950 Leer, W Germany
Koch Motorrad GmbH, Schlagstr.31/33, 3442 Wanfried, W Germany. Phone 05655.8051
Jorg Daum, An den Birnbaumen 1, 3470 Hoxter, W Germany. Phone 05271.7347
H-P Hommes, Ompertterweg 106, 4060 Vierseu 1, W Germany. Phone 02162.23201
Wuatenbofer, Deutscherstr. 98/100, 4600 Dortmund-Eving, W Germany. Phone 0231.852281
Leicht & Spring, Landsbergerstr.88, 8901 Konigsbrunn, W Germany. Phone 08231.86252
Reinhold Martin, Karlstr.5, D2860 Osterholz-Scharmbeck, W.Germany 04791/3776

Ulrich Klinger, Carl Schurz Str. 16, D-6070 Langen, W.Germany.
Hans-Dieter Petersmeier, Friedrich-Wilhelms-Bleiche 8a, 4800 Bielefeld 14,
W Germany. Phone 0521.452445
Martin Kornhas, Durlacher Allee 105, 7500 Karlsruhe 1, W Germany
Phone 0721.617751, 36681.
R S Gardener, Chaussee de la Croix, 81 1340-Ottignies, Belgium. Phone ? 00320;0.413160
Arnold Smits, Margrietstraat 10, Veyhel, Holland. Phone 04130.62603
Leonard Mott, Van Citterstraat 18, St Laurens, Middleburg, Zeeland, Holland.
Phone 0180.37660
A Moushouwer, Drycrselaan 14, Gorinchem 4205 ZJ, Holland. Phone 1830.23098

Same Dated Addresses - Worth a try?

Nordmotor, Norderstr. 128, 239 Flensburg, W Germany. Phone 0461.26500.
T.F. & H., Hafendamm 46, 239 Flensburg, W Germany.
Peter Ondrak, Ungererstr. 137, D-8 Munchen 40, W Germany. Phone 089.325428.
A Fischer, Hess str. 4, 8 Munchen 40, W Germany. Phone 089.286909.
Sundmotor, Schwanthalerstr. 5, 8 Munchen 2, W Germany. Phone 089.555640.
Motorrad Lamers, Hauptstr. 25, 8031 Olching, W Germany. Phone 08142.13891
Motorrad Centre, Schulstr. 25, 7081 Essingen Bei Aalen, W Germany. Phone 07365.218
Detlev Louis, Rentzelstr.7, Hamburg 13, W Germany.

OTHER PARTS - HOME & ABROAD

Bing Carburettors

Fritz Hintermyer GmbH, Postfach 57, 8500 Nurnberg 133, W Germany.
Amal, Holdford Rd, Witton, Birmingham B6 7ES. Phone 021.356.4801.

Amal & Fischer Amal Carburettors

Amal, Holdford Rd., Witton, Birmingham B6 7ES. Tel: 021.356.4801
Arrow Components, 47 Chesterwood Rd., Birmingham. B13 0RG

Reinz Gaskets & Oil Seals

Reinz Dichtung GmbH, Postfach 1909, 7901 Neu Ulm, W Germany.
J Payen Ltd., P O Box 18, Edinburgh Ave, Slough, Bucks, SL1 8TG
Chillcots Ltd, 80 Newlands Park, Sydenham, London SE26 5ND

Bosch & Noris Equipment

Robert Bosch GmbH, Postfach 50, 7 Stuttgart 1, W Germany.

Petrol Taps

Karlcoma Armaturen GmbH, Postfach 40, D 7032 Sindelfingen 6, W Germany.

Filters

Knecht GmbH, Postfach 669, 7000 Stuttgart, W Germany
Coopers Filtration Ltd., Hemel Hempstead, Herts, HP2 7ES. Phone 0442.50311.
Crosland Filters Ltd., Glaisdale Drive East, Nottingham. Phone Notts 291145

Seat Recovering

Form, Unit 5, Springvale Mill, Waterside Rd, Rossendale, Lancs BB4 5EG.
Phone 0706.227857.
R K Leighton (Upholstery), Unit 6, Gunsmith House, 50/54 Price Street, Birmingham.
B4 6JZ. Phone 0385.0514.
Addons, 20 Webb Crescent, Chipping Norton, Oxford OX7 5HU

Valves & Guides

Farnborough Engineering Co Ltd, Farnborough, Orpington, Kent.

Pistons & Rings

A.E. Autoparts Ltd, PO Box 12, Legrams Lane, Bradford, W. Yorks., BD7 1NQ
I.Sier Group Ltd., Kemp House, 152/160 City Rd., London EC1V 2PE. Tel:01.253.6173
& 7515 (ask for Mr King)

Manuals

Schober, Postfach 5806, 68 Mannheim, W. Germany. Tel: 0621/812468
WK-Verlag, Lageschestr.105, 4902 Bad Salzufflen 1, W. Germany.

Sidocar Parts

W Barker, 14 Derek Rd., Whittle-le-Woods, Chorley, Lancs. PR6 7LZ Tel:02572.77942
Kunststoffteile Klimek, Neulander Elbdeich 118, 21 Hamburg 90, W Germany.
Phone 040.76752069
Motorrad Stemler, Garschager Heide 29, 5330 Remscheid 11, Lutinghausen, W Germany.
Phone 02191.50639

Silencers / Exhausts

Breakwell & Green, Chatsworth Ave, Long Easton, Notts. Phone 0602.735016.
Keihan Systems, Unit 4, Dunlop Road, Hunt End Ind Est., Redditch, Worcs.
Phone 0527.46860.
Otto Armeier, Alpenstr, Karl-Emmingerstr 25, A-5020 Salzburg, Austria

Exhaust Spanners

F Barton, Dinckley House, Dinckley Square, Blackburn, Lancs. Phone 0254.62558.

Number Plates

J Yates, 14 Hall Hill, Bollington, Macclesfield, Cheshire SK10 5ED. Phone 0625.72093

Socket Covers

Guy Osbourne, O & S Motorcycles. Phone 021.326.8674.

Tairings (replica Avon)

Sprint Manufacturing, 30B Upton Lovel, Nr Warminster, Wilts. Phone 0985.50821

Stainless Fasteners

Keith Shaw, 5 Banbury Av, Toton, Long Eaton, Notts. Phone Long Eaton 727847
L D Middleton, Unit SE, Peel Mills, Commercial St, Morley, Leeds LS27 8AG.
Phone 0532.524488

Crankshaft Reconditioning

S.E.P., Kegworth, Leics.

Trevor Hopkinson, Engine Machining Services, Kirkham Works, Central Ave., Worksop,
Notts. Tel: 482649 Or 477019 (home)

Speedo/instrument Repairs

Mr Bradshaw, Bristol Instruments, Templar House, Temple Way, Bristol. Tel: 268103
Vintage Restorations, The Old Bakery, Windmill St., Tunbridge Wells, Kent TN2 4UU
Tel: 0892.25899

Availability of Monograde Lubricants

Batoye Ltd, P O Box 319, Colne Vale Rd, Milnsbridge, Huddersfield HD3 4NT.
Phone 0484.642015
Castrol Ltd, Burma House, Pipers Way, Swindon, Wilts SN3 1RE. Phone 0793.30151
Century Oils, PO Box 2, Century Works, Hanley, Stoke on Trent, Staffs. ST1 5HU
Phone 0782.29521
Comma Oils & Chemicals Ltd, Comma Works, Darford, Kent DA1 1PQ. Phone 322.22351
Dalton & Co Ltd, Sikolene Oil Refinery, Belper, Derbys DE5 1WF. Phone 077382 4151
Elf Filling Stations should have SAE 30.
Filtrate Ltd, P O Box 67, Kidacre St, Leeds LS1 1LS. Phone 0532 450773
GB Lubricants Ltd, Albany Road, Gateshead NE8 3BP. Phone 0632.774221
Meteor Oil Co, Tinsley St, Great Bridge, Staffs DY4 7LG. Phone 021.557.9508.
Morris & Co (Shrewsbury) Ltd, Castle Foregate, Shrewsbury, Salop. Phone 0743 .52431
R L Morris & Son Ltd, Wellington St, Salford, M3 6LJ. Phone 061.832.4573
Ernest Newton Ltd, Holt St, Birmingham B7 4BB. Phone 021.359.1355/7.
Star Lubricants Ltd, Pipewellgate, Gateshead, Tyne & Wear, NE8 7BN.
Phone 0522.26192
Valvolene Oil Co Ltd, Dock Road, Birkenhead, Merseyside L41 1DR. Phone 051.652.1551.
Velvone Oils Ltd, Ditton Road, Widness, Cheshire WA8 0NN. Phone 051.424.2488

BMW Club Technical Library

The Club's technical library of handbooks, workshop manuals, parts lists and road tests is far from complete, and may be added to at any time if any members feel inclined to donate to it.

Our Club Vintage Secretary will make whatever arrangements he can to copy information from the technical library to members on receipt of an enquiry and subsequent payment of copy and postage costs. This listing details the information currently held.

	Model	English	German	Rider Handbook	Workshop Manual	List	Diagram	Parts	Info.	Other Tech. Info.	Road Tests
R32											
R37											
R42											
R47											
R52											
R57											
R62											
R63											
R11		*									
R16		*								*	
R12	*			*	*	*	*	*	*	*	*
R17	*	*		*	*	*	*	*	*	*	*
R5	*								*	*	
R6									*		
R51	*				*	*	*	*	*	*	*
R51SS	*				*	*	*	*	*	*	*
R61	*				*	*	*	*	*	*	*
R66	*				*	*	*	*	*	*	*
R71	*				*	*	*	*	*	*	*
R75		*			*	*	*	*	*	*	*
R35									*		
R20									*		
R23									*	*	
R24					*	*	*	*	*	*	*
R25	*		*	*	*	*	*	*	*	*	*
R51/2	*			*	*	*	*	*	*	*	*
R51/3	*		*	*	*	*	*	*	*	*	*
R67	*		*						*		
R67/2			*	*	*	*	*	*	*	*	*
R68				*	*	*	*	*	*	*	*
R67/3				*	*	*	*	*	*	*	*
R50	*		*	*	*	*	*	*	*	*	*
R69	*		*	*	*	*	*	*	*	*	*
R60	*		*	*	*	*	*	*	*	*	*
R50S	*		*	*	*	*	*	*	*	*	*
R69S	*		*	*	*	*	*	*	*	*	*
R39											
R2 6ps											
R4 12ps											
R2 8ps											
R4 14ps											
R3											
R25/2				*	*	*	*	*	*	*	*
R25/3	*			*	*	*	*	*	*	*	*
R26	*		*	*	*	*	*	*	*	*	*
R27	*	*	*	*	*	*	*	*	*	*	*

	Model	English	German	Rider Handbook	Workshop Manual	List	Diagram	Parts	Info.	Other Tech. Info.	Road Tests
R50/5	*		*					*	*	*	*
R60/5	*		*					*	*	*	*
R75/5	*		*					*	*	*	*
R60/6	*		*					*	*	*	*
R75/6	*		*					*	*	*	*
R90/6	*		*					*	*	*	*
R90S	*		*					*	*	*	*
R60/7											
R75/7											
R100/7											
R100S											
R80/7									*		
R100RS											
R45			*								
R65			*								
R100T											
R100RT											
R100CS											
R65LS											
R80RT											
K Series											
K100			*								
K100RS			*								
K100RT			*								
K75											
K75C											
K75S											
Mono-lever Twins											
R80G/S											
Paris/Dakar											
R80ST											
R65											
R80											
R80RT											
R100RS											
R100RT											
Para-lever Twins											
R80G/S										*	
R100G/S											

MISCELLANEOUS PUBLICATIONS IN THE TECHNICAL LIBRARY

Mechanical

Tool drawings for R24, R25, R51/2, R51/3 & R67
Gasket lists for R24, R25, R25/2, R25/3 & R26
Reinz Dichtung gasket lists for R51/2, R51/3, R67/2, R67/3, R68, R50, R50S, R60,
R69 & R69S
Bearing and oil seal details for R27
Bing carburettor details for virtually every BMW 1931 to 1968.
1954 492cc Rennsport
Fitting instructions for twin RS & RT fairings.

Electrical

Part book, Bosch electrics - pre war.
Wiring diagrams for R12 magneto ignition, R24, R25/3, R51/2, R26, R27,
R51/3, R67, R67/2, R50, R50S, R60, R69, R60US,
R100RS(1977), R100RS & RT (1978)(1979) & (1980)
Wiring diagrams for...../5 series, /6 series, & R90S.
Wiring diagrams for.....R45 & R65.
Leaflet on Bosch RD45 & REA50 watt generators (inc. wiring diagram)
Bosch spare parts list for magneto MZad/R (about 1951 - 54) in German.
Bosch instruction & maintenance sheets for MZad/R magneto & L45/60/L dynamo (1951-54)
Bosch D2B R (L) 900 magdynamo.....in German.
Electrical equipment 1934 - 52in German.
Bosch electrical data for R67, R67/2, R67/3, R68 & R69.....in German.

J.G 6v - 12v conversion description.
J.G 6v - 12v conversion instructions.
D.I.Y. 6v - 12v conversion.
Bosch W5AC (W225T1) Sparking plugs - good for post vintage and post war bikes.

Publicity Material

Sales leaflets for R52, R57, R62, & R63.....in German.
Price lists for R2, R52, R57, R62, R11, R63 & R16in German.
Sales leaflet for R52, R57, R11, R16.
Sales leaflet for R2, R4, R12, & R17.....in English & German.
Sales leaflet for R51, R61, R66, R71, R23 & R35.
Sales leaflet for R25/3, R51/3 & R67/2.

Sidecar Information

Steib developments 1953

Steib Parts Lists (in German) -	TR500	LT200
	S500L	RS1
	S350	Fittings
	LS200	

VERY RECENT NEWS:

Following a clear-out of old stock BMW Netherlands have sold all their pre-'69 model and series 5 (/5) parts to

H.H.G. Van Donkelaar, Vaartweg 26 A-E, Hilversum, Netherlands. Tel:02150.48917

Josef Paffen, 2930 Varel, West Germany, has bought all BMW AG factory spares for BMW 'oldies' from 1948 to 1969
